

Constrained Beamforming for Space GPS Navigation

Alison Brown and Ben Mathews, *NAVSYS Corporation*

BIOGRAPHY

Alison Brown is the President and CEO of NAVSYS Corporation. She has a PhD in Mechanics, Aerospace, and Nuclear Engineering from UCLA, an MS in Aeronautics and Astronautics from MIT, and an MA in Engineering from Cambridge University. She was a member of the GPS-3 Independent Review Team and the Interagency GPS Executive Board Independent Advisory Team, and is an Editor of GPS World Magazine. She is an ION Fellow and an Honorary Fellow of Sidney Sussex College, Cambridge.

Ben Mathews is the manager of the Digital Signal Processing, Modeling, and Simulation Section at NAVSYS Corporation. His work includes the design and development of NAVSYS' advanced GPS systems including digital beam-steering receivers, GPS jammer geolocation systems, and network-assisted GPS systems. He holds a MSEE from Virginia Tech.

ABSTRACT

NAVSYS Corporation has developed a prototype for a flexible, high-performance Space-based Software GPS Receiver (SSGR) to demonstrate the next generation of tracking and navigation capabilities for space applications. Based on a Software Defined Radio (SDR) approach, the SSGR will provide an integrated precision navigation and attitude determination solution for space applications. In order to support GPS signal tracking in the space environment, a constrained beamforming algorithm tailored to the space environment has been developed that will allow satellites to track weak GPS signals even in very close proximity to other GPS satellites. In this paper we present the theoretical development of this algorithm, details of its deployment on the SSGR, and test results using the NAVSYS Advanced GPS Hybrid Simulator.

The ability to track low power GPS satellites in the presence of much stronger GPS signals will extend the use of GPS for precision navigation and timing, particularly for high altitude space missions (above the GPS satellite constellation). With this capability, the SSGR will be suitable for supporting multiple space

missions including GPS metric tracking during launch, orbit determination during transfer to geostationary orbits, and high accuracy navigation, attitude control, and timing. The flexibility of the SSGR design will allow it to be reprogrammed for use in launch and orbit entry, station keeping, and autonomous orbit estimation applications.

INTRODUCTION

Spaceborne GPS technology is being widely accepted by both the commercial space industry and by NASA as the key enabler for improving space operations. GPS applications include: autonomous orbit operations, accurate positioning and time synchronization, attitude determination and accurate relative ranging between vehicles for formation flying.

NAVSYS has developed an innovative 3-D digital beam-steering antenna array to provide a high accuracy combined navigation/attitude space Space-based Software GPS Receiver (SSGR). Our approach leveraged the 2-D digital beam-steering GPS receiver technology previously developed by NAVSYS as a commercial product⁽¹⁾.

The SSGR design has been optimized to address the various complications of space-based GPS usage. The receiver must have the capability to maintain lock through dynamic maneuvers and in challenging signal environments; both during launch and orbit transitions. GPS visibility must be maintained even for spinning satellites and when the satellite is in higher orbit than GPS orbit. The use of beam steering to aid the GPS tracking and recovery during outages gives the receiver the ability to maintain lock in situations where single-element solutions would fail. The Digital Beam Steering (DBS) capability utilized in the SSGR allows for the construction of a composite GPS signal from multiple non-coplanar antenna elements placed around the spacecraft. The beam steering/null forming functionality also allows for tracking of weak GPS signals (such as GPS sidelobes) from higher than GPS orbit.

SSGR HARDWARE

The SSGR is based on a Software Defined Radio (SDR) design as shown in Figure 1. This includes an RF component which performs the digitization of each of up

to 16 antenna elements which are then processed in two Xilinx FPGA boards. The Digital Beamsteering (DBS) board performs the digital beam-forming and the Correlator Accelerator Card (CAC) board performs the GPS correlation functions. The SDR and beam-steering algorithms provide flexibility in how the antennas can be configured on a spacecraft. In the configuration shown in Figure 1, the antennas include two elements on the reverse side of the satellite to provide all-around visibility, and two sub-arrays of 7-elements each on the primary satellite axis, data from which can be combined to provide nulling in the direction of any multipath signals.

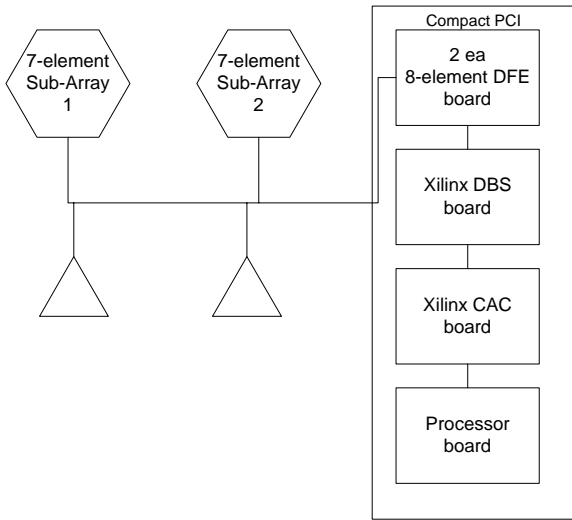

Figure 1 SSGR Design



Figure 2 16-Element L1 Only Rack-Mounted SSGR

The SSGR components can be assembled in a variety of different configurations for testing. The intent is to port the SSGR software and firmware ultimately to a space qualified SDR for a production system. For the initial testing, the rack-mounted configuration shown in Figure 2 was used.

SSGR FIRMWARE

The SSGR firmware design has been implemented in Xilinx logic to run on the SDR Digital Signal Processing (DSP) board. This performs the beam/null-steering functions and the code/carrier correlations.

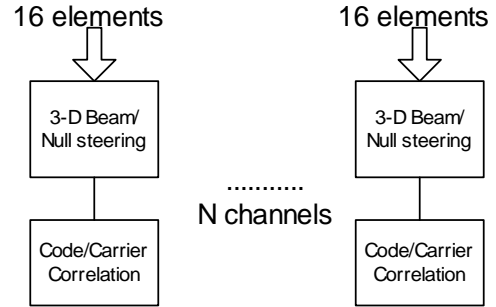

Figure 3 Digital Beam/Null-Steering Firmware Functions

The individual complex weights used to perform the digital spatial processing are computed by the SSGR software and downloaded to the SSGR DBS board where they are applied. The complex weights downloaded from the computer can be used to select any combination of the 16 antenna elements to be fed to an individual satellite channel. The SSGR design allows for up to 24 satellite channels to be configured (N=24). These can be allocated through software control for either tracking 24 satellites using a combination of all 16 antenna elements – i.e. in a 4π steridian mode of operation. Alternatively the channels can be allocated so that half are assigned to tracking satellites from one sub-array and the second half from a second sub-array to provide dual sets of measurements for attitude determination, using the SSGR system configuration illustrated in Figure 1, where two sub-arrays of 7-elements each are used with weighting applied to place beams and nulls in the desired directions.

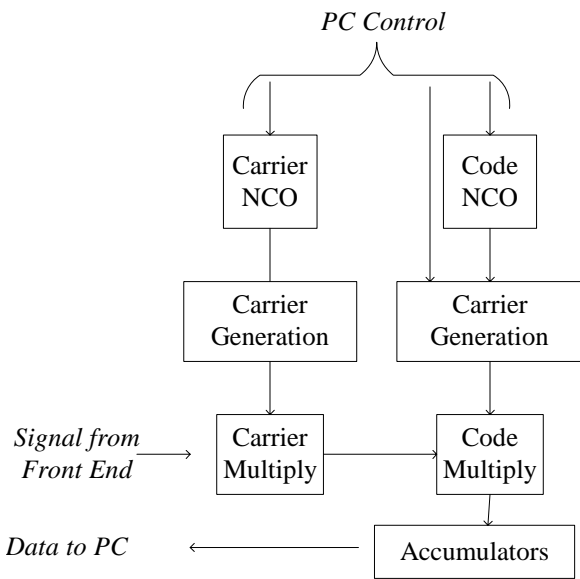

Figure 4 Correlator Functions

Code Correlation and Tracking

The code correlation and tracking functions include the steps of code generation for the C/A code for each satellite channel selected, code correlation and complex multiplication to remove the effect of the Doppler on the satellite signal.

SSGR SOFTWARE

The SSGR software has been developed as an upgrade to the existing digital beam forming and GPS navigation software developed for use in our High Gain Advanced GPS Receiver (HAGR)^[2]. The HAGR software is coded in the C-language using an object-oriented approach, with additional functionality provided by Matlab-based signal processing and navigation algorithms. In Figure 5 the existing software modules that will be used in the final SSGR design are illustrated (the shaded blocks) with the software modules that were modified for space operations.

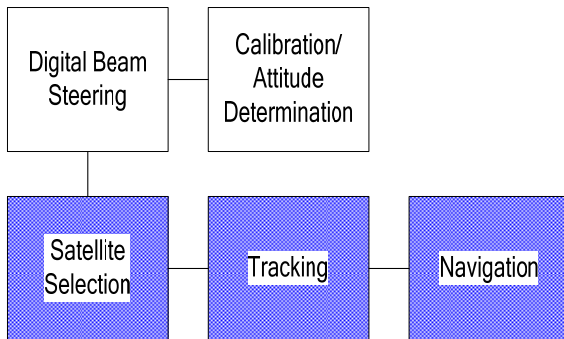

Figure 5 SSGR Software Modules

Digital Beam-Steering (DBS)

The DBS module operates the interface to the DSP digital beam steering firmware and Matlab functions. This computes the weights for the complex multiplication and accumulation functions. The weights are computed to perform the beam/null-steering to maximize the power in the direction of the desired satellite signal and minimize it in the direction of any undesired high power signals. This module can run at a rate of up to 20 Hz to accommodate tracking from a rotating space vehicle.

Calibration/Attitude Determination Function

The SSGR calibration function operates by processing the individual antenna elements to estimate the calibration offsets needed to perform beamforming, and also estimate the antenna attitude.

Satellite Selection

The satellite selection module determines which satellites are in the field of view of the receiver. This module was modified to accommodate satellite blockage by the earth and compute the expected satellite visibility based on the sidelobe and mainlobe of the GPS antenna patterns (see Figure 6 and Figure 7). For example, satellites in orbits above the GPS signals will only see the GPS mainlobe for satellites on the other side the earth. However, the sidelobes can also be periodically tracked as the GPS satellites orbit the earth. This module calculates the visible satellites and estimates the received power at the spacecraft. This data is used to select which satellites to track and also to determine when strong signals are present that need to be nulled to reduce/eliminate cross-correlation sources and allow weak signal tracking of other GPS satellite signals.

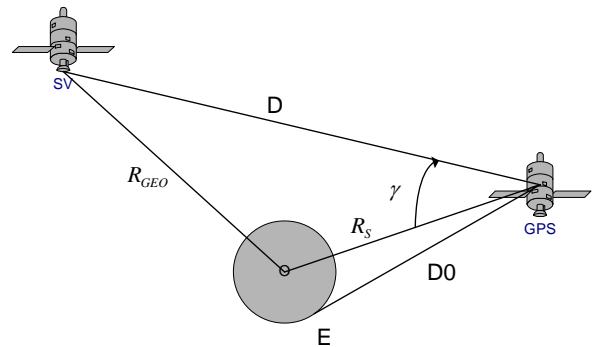

Figure 6 GPS-to-Spacecraft Geometry

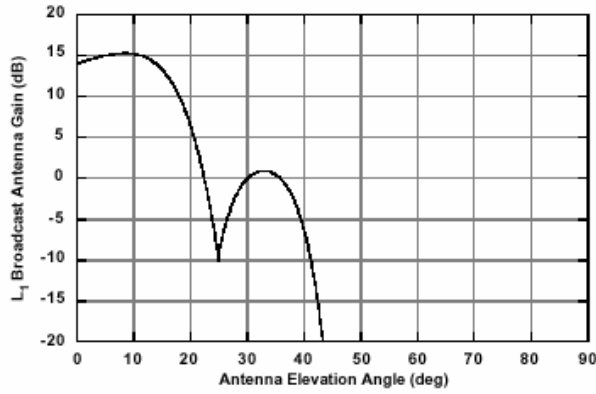

Figure 7 GPS II/II-A Gain Pattern

Tracking

The tracking module implements the code delay locked loop and carrier tracking functions on each of the channels of data output by the DSP board. This includes both the beam forming and the calibration channel outputs. Conventional GPS UE generally use 1 msec accumulated I and Q values, as this is convenient for detecting the data bit transitions. In Figure 8 the Pcd values are plotted for different accumulation times from 100 msec to 100 secs. The longer the accumulation time, the lower the satellite C/N0 that can be detected. Detection thresholds are generally set at around 95% probability. This equates to a post-accumulation signal/noise level of around 8 dB. The C/N0 that can be detected with a probability of correct detection of 95% is plotted in Figure 8 as a function of the total processing accumulation time. For example, with a 1 second accumulation of 1 msec data (1000 non-coherent accumulations) the C/N0 detection threshold is 21.4 dB-Hz. With 20 msec coherent accumulations over the same 1 sec time interval (50 non-coherent accumulations) the C/N0 detection threshold is 15.7 dB-Hz. If navigation data bit aiding is used to remove the data-bit modulation then the fully coherent (FC) GPS signals can be integrated further using Doppler removal from the navigation solution and the estimated orbit allowing weak signal tracking to a 10 dB-Hz threshold over 1 second.

Navigation

The navigation module processes the received GPS signals to compute the GPS navigation solution. This mode includes stand-alone navigation, which will be used for testing, and also an integrated GPS/inertial Kalman Filter using our InterNav software^[3]. The predicted orbit position, velocity and attitude data is used to aid the beamforming and also to remove the Doppler effects to allow weak signal tracking.

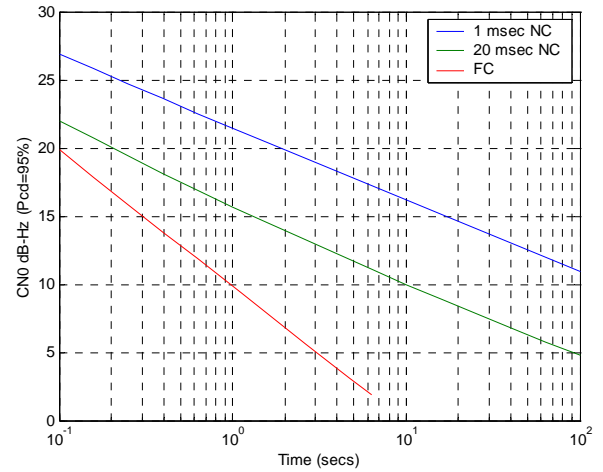

Figure 8 C/N0 Detection Threshold versus Accumulation Time (Pcd=95%)

BEAMFORMING APPROACH

When operating on a satellite that is in close proximity with either one of the MEO GPS broadcasts, or a GPS geostationary augmentation signal, the high power GPS signal can cause cross-correlations with any lower power GPS signals, resulting in false locks. This problem is termed, the “near-far” problem. With the GPS C/A codes false locks can occur whenever the relative signal power between two GPS satellites exceeds 24 dB. This can easily occur when operating with GPS satellite signals at both high power (e.g. close-in) and low power (e.g. sidelobes) levels.

To prevent this false lock, the array gain pattern can be formed to have low gain in the direction of the strong satellite signal and high gain in the direction of the weak satellite signal. At the same time the beam pattern should reject noise as much as possible. Assuming the power received from each of the satellites as well as the noise power can be estimated, we can create a model spatial correlation matrix. Since the strong signals are all received from approximately the same direction, they can be considered as a single signal with power equal to the sum of the power of all strong signals. The model spatial correlation matrix is calculated as follows:

$$\hat{R}_{ss} = \begin{bmatrix} P_{sv,i} & 0 \\ 0 & \sum_{j \neq i} P_{sv,j} \end{bmatrix} + \sigma_n^2 I \quad \text{(Equation 1)}$$

Where

$P_{sv,i}$ the power of the weak signal to be tracked from the i-th satellite

$P_{sv,j}$ the power of the interfering signal from the j-th satellite

σ_n^2 the noise power (or covariance)

The optimal weight vector is the solution of the constrained optimization:

$$\min_w \underline{w}^H \hat{R}_{ss} \underline{w} \quad \text{subject to:} \quad Cw = c$$

with:

C the constraint matrix: $\begin{bmatrix} e_{sv,i} & \frac{\partial e_{sv,j}}{\partial \phi_j} & \frac{\partial e_{sv,j}}{\partial \theta_j} \end{bmatrix}^H$

c the constraining values: $\begin{bmatrix} 1 & 0 & 0 \end{bmatrix}^T$

$e_{sv,i}$ the steering vector corresponding to the direction of the desired satellite signal

$e_{sv,j}$ the steering vector corresponding to the direction of the interfering satellite signals

ϕ_j the azimuth of the interfering satellites in the array frame

θ_j the elevation of the interfering satellites in the array frame

The (closed form) solution to this problem is calculated as:

$$\underline{w}_\diamond = \hat{R}_{ss}^{-1} C^H (C \hat{R}_{ss}^{-1} C^H)^{-1} c$$

Figure 9 shows an example of the gain pattern that is calculated with this constraint.

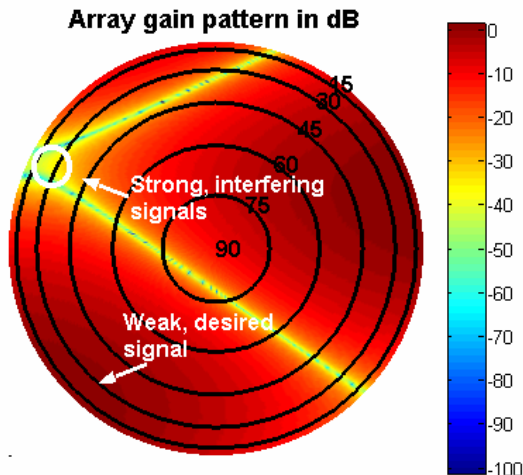

Figure 9 Gain pattern to null a range of directions

SIMULATION ENVIRONMENT

One of the biggest challenges of designing a space-based GPS receiver is testing, since the dynamics involved are radically different from anything achievable on the ground. Commercially available GPS simulators that can simulate the space environment are very expensive, generally have high learning curves, and are limited in capability. The multi-element Advanced GPS Hybrid Simulator (AGHS)^[4] designed by NAVSYS addresses many of these concerns and was used to test performance of the SSGR design. The AGHS generates simulated digital signal sets using profiles generated by NAVSYS' MATLAB GPS Toolbox that can be used to generate digital representations for the GPS signals under the various scenarios for playback the GPS receiver under test. The Simulink User Interface shown in Figure 10 provides the user high fidelity control of both the simulated signal and also the simulated error conditions.

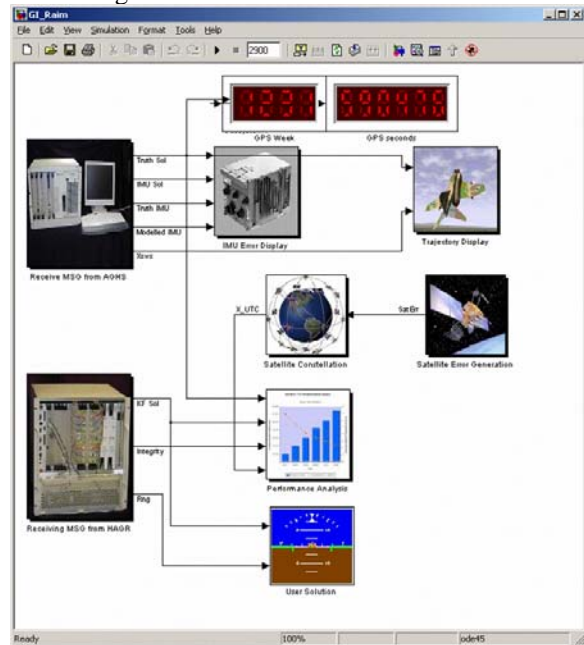

Figure 10: AGHS Simulink model

The enhanced AGHS architecture allows access to all levels of satellite signal generator control through NAVSYS' MATLAB[®] satellite and signal generation scripts, and its software interface for insertion of future GPS signals or simulated jammer waveforms onto composite digital satellite signal profile. To support the development and testing of beamsteering receivers, the AGHS is capable of high-fidelity, phase-coherent RF wavefront generation.

Under a Phase II SBIR contract with NASA's Goddard Space Flight Center, the enhanced AGHS system and NAVSYS Matlab Signal Simulation Toolbox were used to test the prototype SSGR and the constrained beamforming algorithm in a variety of orbit profiles. The tests focused on the SSGR's ability to acquire and track

GPS satellite signals for high altitude orbits (40000 km) and the performance of space-optimized beamforming algorithms for low-power tracking.

ATTITUDE ESTIMATION

To perform beamforming towards the satellite, the attitude of the spacecraft must be known. This is estimated by combining the antenna element signals to observe the 3D attitude using an estimation algorithm. Simulation results of the 3D attitude estimation algorithm are shown in Figure 11, Figure 12, and Figure 13. As can be seen in these figures, the algorithm is able to perfectly resolve pitch, roll, and heading within 1 degree of precision.

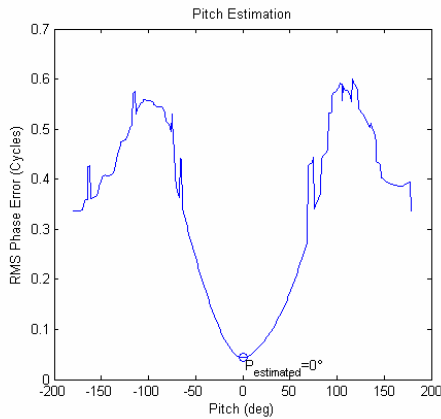

Figure 11 Pitch Estimation

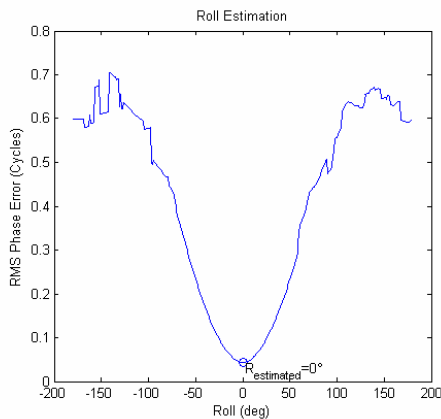

Figure 12 Roll Estimation

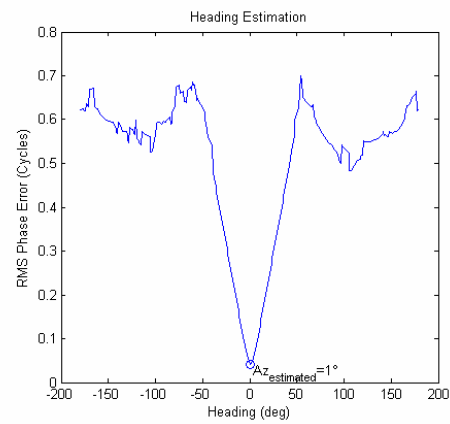

Figure 13 Heading Estimation

BEAMFORMING AND LOW POWER TRACKING

A simulation was run to show the relative advantages of beamsteering and beamnulling over single-element processing on low power GPS signal tracking in a space environment. In this test all SVs except for SV 29 are held at a nominal CN0 of 45 dB-Hz, and the CN0 for SV29 is slowly ramped down from 45 dB-Hz to 25 dB-Hz in order to determine the CN0 threshold at which the SSGR stops tracking using the three different processing schemes.

The results of this test are shown in Figure 14. Both conventional beamsteering and beamnulling outperform single-element tracking. Figure 15 shows a zoomed-in view of the breakdown points at which the SSGR stops tracking, and shows that both array processing approaches yield approximately a 4 dB improvement in weak signal tracking performance.

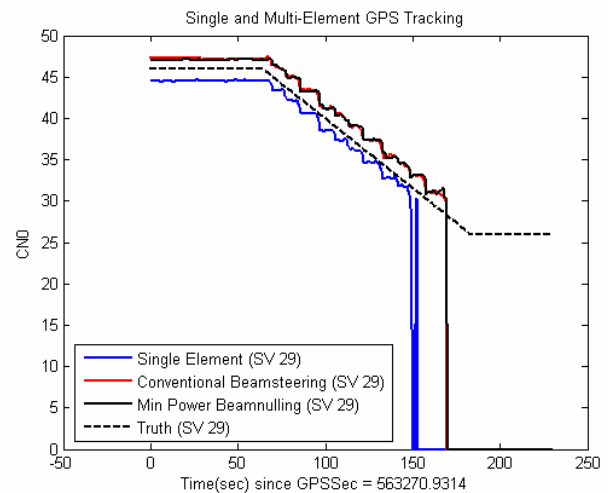

Figure 14 Low Power Tracking Results

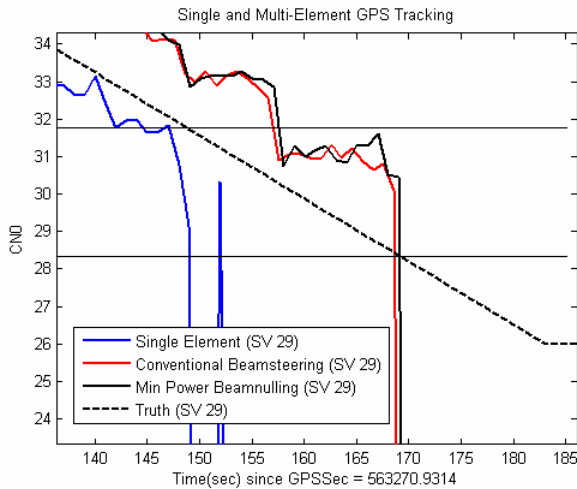

Figure 15 Low Power Tracking Results (Detail)

Both conventional beamsteering and the beamnulling offer nearly identical performance in this test since there is no strong GPS signal received that would provide interference through cross-correlation.

A constellation configuration was selected that presents a worst-case scenario for GPS tracking channels false locking onto strong interfering signals. In this configuration all SVs are held at a constant C/N0 except for SV 17, which is ramped up from 45 dB/Hz to 85 dB/Hz over the course of the test. The test results are shown in Figure 16. It can be seen that under high cross-correlation conditions conventional beamforming actually performs worse than single-element tracking. Subsequent analysis revealed that this effect is due to the fact that placing interferers in the mainbeam results in an increased noise floor and lower C/N0 values. The beamnulling algorithm was able to steer a null in the direction of the nearby interferer and keep it from increasing the noise floor. As a result, the beamnulling algorithm was able to track under conditions where single-element and beamsteering algorithms could not.

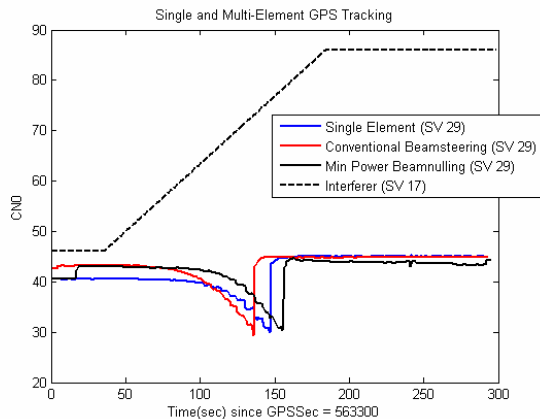

Figure 16 High/Low Power Tracking Test Results

CONCLUSION

The 3D beamforming design of the SSGR allows implementation of an adaptive beamsteering/nulling algorithm that is optimized for space navigation applications. This beamsteering/nulling algorithm outperforms standard single-element and beamsteering approaches and offers a viable approach to GPS satellite tracking in space environments where there is a combination of strong and weak GPS satellite signals. The 3D beamforming also allows both the main-lobe and the side-lobes of the GPS signals to be tracked.

The SSGR software and firmware were developed to allow porting onto space qualified software defined radios. With further development, the prototype SSGR has the potential to provide a flexible, robust navigation capability that can be leveraged by a variety of NASA, civilian and DoD space, launch and space support missions. This highly competitive alternative to existing navigation and tracking products can provide a low cost, high performance competitive alternative to existing GPS receivers.

ACKNOWLEDGMENTS

This work was supported through a Phase II SBIR contract with NASA's Goddard Space Flight Center.

REFERENCES

- [1] D. Sullivan, R. Silva, and A. Brown, "High Accuracy Differential and Kinematic GPS Positioning using a Digital Beam Steering Receiver," Proceedings of 2002 Core Technologies for Space Systems Conference, Colorado Springs, CO, November 2002
- [2] <http://www.navsys.com/Products/hagr.htm>
- [3] <http://www.navsys.com/Products/internav.htm>
- [4] <http://www.navsys.com/Products/aghs.htm>